



H A Harman International Company

C 562 CM

Boundary Layer Microphone

Description

The C 562 CM offers the inherent advantages of a boundary layer design: 6 dB higher sensitivity and virtual elimination of comb filter effects when installed into reflecting surfaces, plus extended and flattened frequency response. The microphone is omnidirectional and offers a superior S/N ratio. The miniature C 562 CM is designed for flush mounting in ceilings, walls, stage sets, etc.. With an attached cable terminating a 3.5 mm (1/8") male jack with threads through the 1/2" mounting hole. An accompanying phantom power adapter provide electronically balanced low impedance output via a 3 Pin XLR-type connector.

Specifications

Transducer Principle:	condenser prepolarized
Frequency Range:	50–15,000 Hz
Polar Pattern:	omnidirectional
Sensitivity at 1,000 Hz:	8.5 mV/Pa (-41 dBV)
Equivalent Noise Level:	< 16 dB-A
Sound Pressure Level for 1 % THD:	130 dB
S/N Ratio (A-weighted):	> 78 dB
Electr. Impedance:	< 600 ohms
Load Impedance:	> 2000 ohms
Power Requirement:	9–52 volts phantom powering
Connector:	3-Pin XLR-type
Cable Length:	3 m (10 ft.)
Finish:	satın nickel
Size:	20 ø/28 mm length (0.8 ø/1.1 in. length)
Net/Shipping Weight:	30 g/195 g (1.1/6.9 oz.)
Special Features/Applications:	boundary layer microphone
Included Accessories:	phantom power adapter
Optional Accessories:	B 18 battery power supply N 62 E, N 66 E AC power supplies

Features

- Small & inconspicuous
- Wide frequency range
- High sensitivity



Architect's and Engineer's Specifications

The microphone shall be a omnidirectional design and shall offer a superior S/N ratio. It shall be designed for flush mounting in ceilings, walls, stage sets, etc., with an attached cable terminating a 3.5 mm (1/8") male jack with threads through the 1/2" mounting hole. An accompanying phantom power adapter shall provide electronically

balanced low impedance output via a 3-Pin XLR connector. Supply voltage shall be 9 to 52 Volts. Colour: satin finish. The microphone shall be an AKG Acoustics C 562 M.

Graphical Data

On-axis Frequency Response (measured at 1 meter)

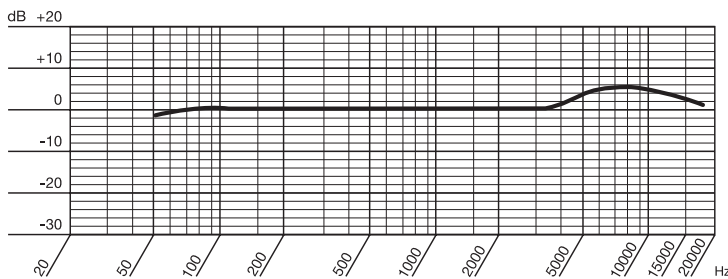

Polar Response

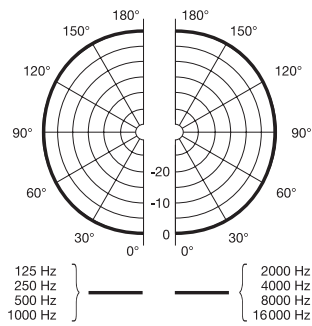

Mounting Data

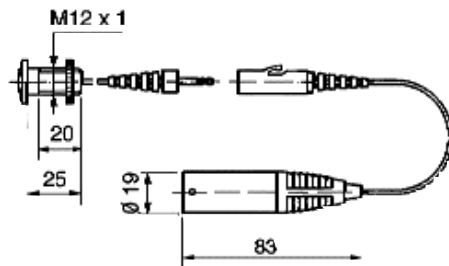

AKG is constantly improving and modifying it's products, therefore, specifications are subject to change without notice.

Limited Warranty

Valid only in the United States. AKG Acoustics warrants AKG products against defects in material or workmanship for a period of one year from the date of original purchase for use, and agrees to repair or, at our option, replace any defective unit without charge for either parts or labor. Important: This warranty does not cover damage resulting from accident, misuse or abuse, lack of reasonable care, the affixing of any attachment not provided with the product, loss of parts or connecting the product to any but the specified receptacles. This warranty is void unless service or repairs are performed by an authorized service center.

No responsibility is assumed for any special, incidental or consequential damages. However, the limitation of any right or remedy shall not be effective where such is prohibited or restricted by law. Simply take or ship you AKG product prepaid to our service department. Be sure to include your sales slip as proof of purchase date. (We will not repair transit damage under the no-charge terms of this warranty.) Note: No other warranty, written or oral is authorized by AKG Acoustics, Inc. This warranty gives you specific legal rights, and you may also have other rights which vary from state to state. Some states do not allow the exclusion or limitation of incidental or consequential damages or limitation on how long an implied warranty lasts, so the above exclusions and limitation may not apply to you.

Microphones · Headphones · Wireless Microphones · Wireless Headphones · Headsets · Electroacoustical Components



H A Harman International Company

AKG Acoustics GmbH
Lemböckgasse 21-25, P.O.B. 158, A-1230 Vienna/AUSTRIA
Tel: (43 1) 86 654-0*, Fax: (43 1) 86 654-516
Internet: <http://www.ake-acoustics.com>

AKG Acoustics; A Division of Harman Pro Germany
Bodenseestraße 228, D-81243 München/GERMANY
Tel: (089) 87 16-0, Fax: (089) 87 16-200

Arbiter Pro Audio
Wilberforce Road, London NW9 6AX/ENGLAND
Tel: (0181) 202 1199, Fax: (0181) 202 7076

AKG ACOUSTICS, U.S.
1449 Donelson Pike, Airpark Business Centre 12,
Nashville, TN 37217, U.S.A.
Tel: (615) 360-0499, Fax: (615) 360-0275

Studer Japan Ltd.
2-43-7, Uehara, Shibuya-ku, Tokyo 151-0064/JAPAN
Tel: (813) 3465-2211, Fax: (813) 3465-2214

Erikson Pro Audio
620 McCaffrey, St-Laurent, Quebec, H4T 1N1, CANADA
Tel: (514) 738-3000, Fax: (514) 737-5069
Internet: www.jam-ind.com/eriksonpro